



Curved Jaw Couplings

Measurements in
Metric Units



Why Choose Guardian?

For more than 70 years, Guardian has been designing and manufacturing world-class couplings and other power transmission components. Utilizing advanced manufacturing technologies and processes, Guardian provides highly-reliable coupling and component solutions to meet the most challenging industrial application requirements.

Guardian provides a wide range of standard and custom products including flywheel couplings, hydraulic pump mounts, bearing supported stub shafts, flexible shaft-to-shaft couplings, motion control couplings as well as compression pipe couplings.

Durable Guardian products are utilized in key industries including mobile hydraulics, farm & ag, tree care, concrete, food & beverage, material handling, automation, power generation, and oil & gas on applications such as skid steers, aerial lifts, harvesters, wood chippers, concrete pumps, dewatering pumps, baggage handlers, conveyors, robotics, compressors, and generator sets.

FEATURES AND ADVANTAGES

The Curved Jaw couplings can be utilized in many applications and serve as an all-purpose coupling. The basic design of the Curved Jaw allows for a higher torque capacity in a compact design. The curved tooth has a greater contact area which gives it the high torque capacity, and reduces edge pressure. It will accommodate axial, radial and angular shaft misalignments.

The hubs are produced from a variety of materials including: aluminum, gray iron, steel, sintered steel, and stainless steel. The spider elements are available in various durometer options in Urethane & Hytrel. The spiders can perform under normal duty cycle conditions to heavy duty cycles which include shock loading and can minimize torsional vibrations in the system.



- **Three Piece Design**
- **Fail Safe**
- **No Lubrication Required**
- **Variable Durometer Urethane Elements**
- **No Metal to Metal Contact**
- **High Torque Capacities**
- **Variable Hub Materials**

COUPLING TORQUE RATINGS AND SPIDERS

The curved jaw coupling includes two metal hubs and an elastomeric “spider” element. The spiders are available in different hardness durometers, each easily identified by its color.

SPIDER CHARACTERISTICS					
Hardness	Color	Material	Temperature Range		Applications
			Standard	Maximum	
80 Shore A	Blue	Polyurethane	-40° to 100° C	121° C	Excellent damping
92 Shore A	White	Polyurethane	-40° to 100° C	121° C	Moderate damping, general applications
98 Shore A	Red	Polyurethane	-40° to 100° C	121° C	High torque applications
64 Shore D	Green	Hytrel	-34° to 110° C	130° C	Higher torque, high temperature

Coupling Size	Spider Color	Torque (Newton meters)			Maximum Speed (RPM)	KW @ 1800 RPM
		Nominal	Maximum	Reversing		
19/24	Blue	4.9	9.7	1.2	14,000	0.9
19/24	White	10.1	19.2	2.6	14,000	1.9
19/24	Red	17.0	33.9	4.4	14,000	3.3
19/24	Green	20.9	41.8	5.2	14,000	4.0
24/32	Blue	17.1	34.0	4.4	10,600	3.2
24/32	White	33.9	68.9	9.0	10,600	6.4
24/32	Red	59.9	119.8	16.0	10,600	11.2
24/32	Green	74.6	149.2	18.6	10,600	14.2
28/38	Blue	46.0	92.0	12.0	8,500	9.0
28/38	White	94.9	189.8	25.0	8,500	18.0
28/38	Red	159.3	319.8	43.1	8,500	30.0
28/38	Green	200.0	400.0	49.9	8,500	38.0
38/45	Blue	93.0	185.0	24.0	7,100	17.9
38/45	White	189.8	379.7	49.0	7,100	35.8
38/45	Red	324.3	649.8	87.0	7,100	61.2
38/45	Green	405.1	810.2	101.2	7,100	76.1
38/45-L	Blue	93.0	185.0	24.0	7,100	17.9
38/45-L	White	189.8	379.7	49.0	7,100	35.8
38/45-L	Red	324.3	649.8	87.0	7,100	61.2
38/45-L	Green	405.1	810.2	101.2	7,100	76.1
42/55	Blue	130.1	260.0	34.0	6,000	24.6
42/55	White	264.4	530.0	69.0	6,000	50.0
42/55	Red	449.7	899.5	120.0	6,000	85.0
42/55	Green	559.9	1119.8	139.9	6,000	105.9
42/55-L	Blue	130.1	260.0	34.0	6,000	24.6
42/55-L	White	264.4	530.0	69.0	6,000	50.0
42/55-L	Red	449.7	899.5	120.0	6,000	85.0
42/55-L	Green	559.9	1119.8	139.9	6,000	105.9
48/60	Blue	150.1	300.0	39.0	5,600	28.3
48/60	White	309.6	615.9	61.0	5,600	58.2
48/60	Red	524.3	1049.8	137.0	5,600	99.2
48/60	Green	654.8	1309.7	163.6	5,600	123.8
55/70	White	409.1	819.3	93.0	4,750	76.8
55/70	Red	684.8	1369.6	163.1	4,750	129.1
55/70	Green	824.9	1649.8	206.2	4,750	155.2
65/75	White	624.9	1249.8	111.0	4,250	117.9
65/75	Red	939.0	1879.2	166.1	4,250	176.8
75/90	White	1279.2	2559.5	254.0	3,550	241.0
75/90	Red	1919.9	3839.7	381.0	3,550	361.8
90/100	White	2400.1	4800.2	624.0	3,550	452.8
90/100	Red	3600.2	7200.4	936.1	3,550	678.9
100/110	White	3299.6	6600.3	858.0	3,550	622.2
100/110	Red	4950.5	9901.1	1287.1	3,550	933.2
110/125	White	4800.2	9600.5	1040.1	3,550	904.9
110/125	Red	7200.4	14401.9	1560.1	3,550	1357.7
125/145	White	6650.1	13301.2	1300.1	3,550	1254.0
125/145	Red	10001.6	20001	1950.2	3,550	1885.9

COUPLING DIMENSIONS

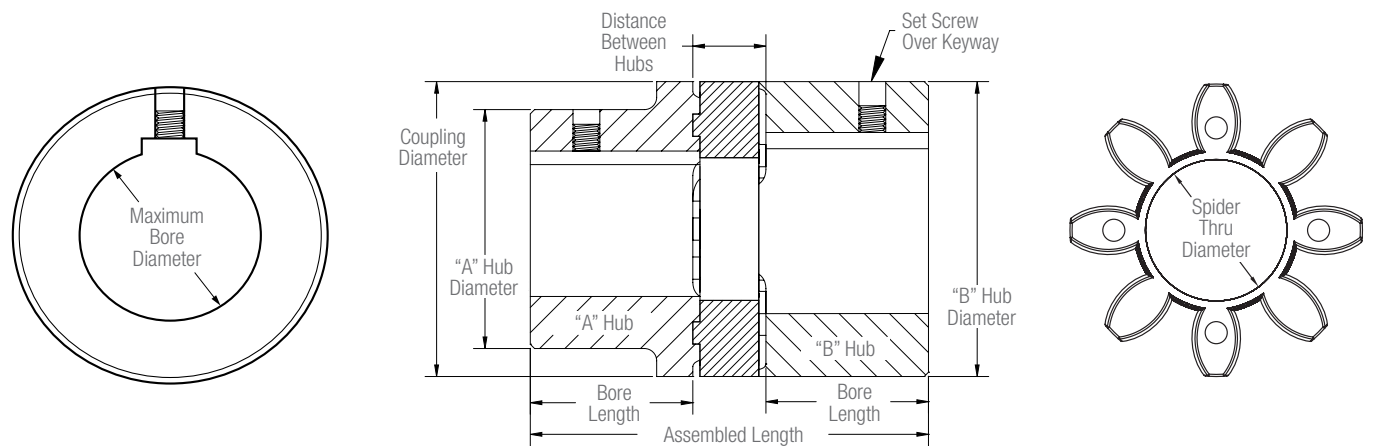

Aluminum Hubs

Size	"A" Hub Min/Max Bore	"B" Hub Min/Max Bore	"A" Hub Diameter	"B" Hub Diameter	Coupling Diameter	Assembled Length	Bore Length (Both A & B)	Between Hubs	Spider Thru Diameter
19/24	6.4/19.1	6.4/24.1	32.0	39.9	39.9	64.8	24.9	14.2	17.8
24/32	Unbored/23.9	8.1/32.0	47.2	N/A	54.9	75.4	29.5	16.0	26.4
28/38	9.4/27.9	9.4/38.1	48.0	64.8	64.8	89.7	35.6	18.5	29.7
38/45	Unbored/38.1	Unbored/45.0	66.0	79.0	79.0	114.3	45.0	24.1	39.9
42/55	15.2/41.9	15.2/55.1	74.9	95.0	95.0	127.0	50.8	25.9	47.2
48/60	12.7/48.0	12.7/59.9	85.1	104.9	104.9	140.0	57.7	27.9	48.5

Sintered Steel Hubs

Size	"A" Hub Min/Max Bore	"B" Hub Min/Max Bore	"A" Hub Diameter	"B" Hub Diameter	Coupling Diameter	Assembled Length	Bore Length (Both A & B)	Between Hubs	Spider Thru Diameter
19/24	N/A	Unbored/24.1	N/A	39.9	39.9	64.8	24.9	14.2	17.8
24/32	N/A	Unbored/32.0	N/A	55.4	55.4	77.0	30.0	16.0	26.4
28/38	N/A	Unbored/38.1	N/A	65.0	65.0	87.6	34.8	18.5	29.7

Stainless Steel Hubs

Size	"A" Hub Min/Max Bore	"B" Hub Min/Max Bore	"A" Hub Diameter	"B" Hub Diameter	Coupling Diameter	Assembled Length	Bore Length (Both A & B)	Between Hubs	Spider Thru Diameter
24/32	N/A	Unbored/32.0	N/A	55.4	55.4	77.0	30.0	0.6	17.8
28/38	N/A	12.7/38.1	N/A	65.0	65.0	87.6	34.8	0.7	29.7
38/45	N/A	12.7/45.0	N/A	80.0	80.0	114.3	45.0	1.0	39.9
48/60	N/A	12.7/60.0	N/A	104.9	104.9	140.0	57.7	1.1	48.5

Steel Hubs

Size	"A" Hub Min/Max Bore	"B" Hub Min/Max Bore	"A" Hub Diameter	"B" Hub Diameter	Coupling Diameter	Assembled Length	Bore Length (Both A & B)	Between Hubs	Spider Thru Diameter
38/45	12.7/38.1	12.7/45.0	66.0	80.3	80.3	114.3	45.0	24.1	39.9
38/45-L	N/A	12.7/45.0	N/A	80.3	80.3	165.1	70.4	24.1	39.9
42/55	15.2/41.9	15.2/55.1	74.9	95.0	95.0	127	50.8	25.9	47.2
42/55-L	N/A	15.2/55.1	N/A	95.0	95.0	174.2	74.9	25.9	47.2
48/60	12.7/48.0	12.7/59.9	85.1	104.9	104.9	140.0	57.7	27.9	48.5
55/70	15.7/55.1	15.7/70.1	98.0	120.1	120.1	160.0	65.0	30.0	60.5
65/75	22.1/65.0	22.1/74.9	115.1	134.9	134.9	184.9	74.9	35.1	67.8
75/90	25.4/74.9	25.4/89.9	135.1	160.0	160.0	210.1	85.6	40.1	91.7
90/100	38.1/89.9	38.1/100.1	160.0	179.8	200.2	245.1	100.1	45.0	100.6

Cast Iron Hubs

Size	"A" Hub Min/Max Bore	"B" Hub Min/Max Bore	"A" Hub Diameter	"B" Hub Diameter	Coupling Diameter	Assembled Length	Bore Length (Both A & B)	Between Hubs	Spider Thru Diameter
90/100	38.1/89.9	38.1/100.1	160.0	179.8	200.2	245.1	100.1	45.0	100.6
100/110	N/A	50.8/110.0	N/A	225.0	225.0	270.0	110.0	50.0	110.5
110/125	N/A	57.7/125.0	N/A	230.1	255.0	294.9	119.9	55.1	124.5
125/145	N/A	57.7/145.0	N/A	264.9	290.1	340.1	140.0	59.9	146.1

MISALIGNMENT

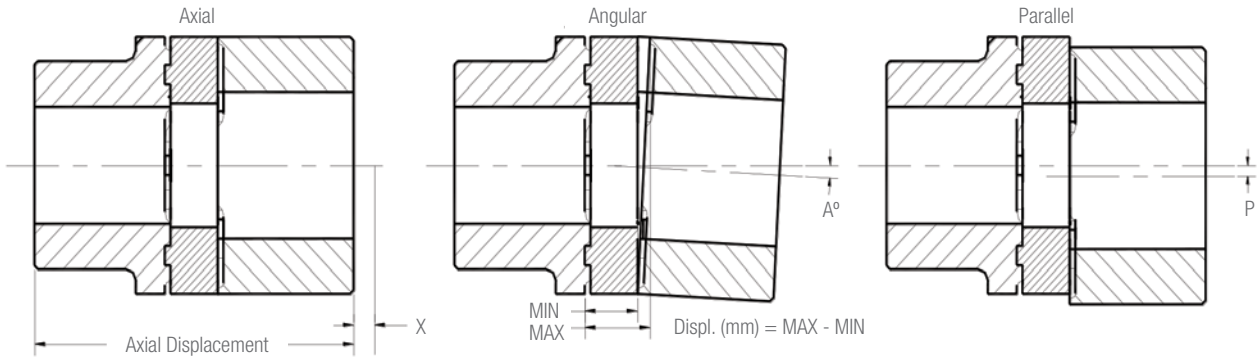

Size	Axial Displacement "X" (Millimeters)	Angular Displacement A° (Degrees/Millimeters)	Parallel Displacement P (Millimeters)
19/24	1.3	1.2 / 0.8	0.2
24/32	1.5	0.9 / 0.8	0.2
28/38	1.5	0.9 / 1.0	0.3
38/45	1.8	1.0 / 1.3	0.3
42/55	2.0	1.0 / 1.8	0.3
48/60	2.0	1.1 / 2.0	0.4
55/70	2.3	1.1 / 2.3	0.4
65/75	2.5	1.2 / 2.8	0.4
75/90	3.0	1.2 / 3.3	0.5
90/100	3.3	1.2 / 4.3	0.5
100/110	3.8	1.2 / 4.8	0.5
110/125	4.3	1.3 / 5.6	0.5
125/145	4.6	1.3 / 6.4	0.6

SET SCREW / CLAMPING INFO

Coupling Size	19/24	24/32	28/38	38/45	42/55	48/60	55/70	65/75	75/90	90/100	100/110	110/125
Location (Y)	9.9	9.9	15.0	15.0	20.1	20.1	20.1	20.1	24.9	30.0	30.0	35.1
Set Screw (S)	1/4-20	5/16-18	5/16-18	5/16-18	3/8-16	3/8-16	1/2-13	1/2-13	1/2-13	3/4-10	3/4-10	3/4-10
Torque (Nm)	9.5	19.0	19.0	19.0	31.2	31.2	67.8	67.8	67.8	226.5	226.5	226.5

HUB OPTIONS

Set Screw & Keyway*

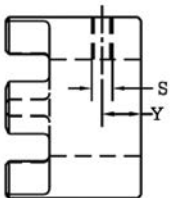

Taper Lock Bushing

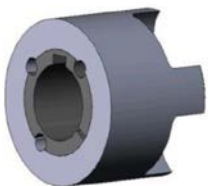

Cross Clamp**



* Standard set screw furnished unless otherwise requested. Metric set screws also available.
 ** SAE Spline with cross clamp feature is a standard offering.

REFERENCE DATA

Standard Bores & Keyseats (in.)		Metric Bores & Keyseats (mm.)	
Bore Range	Keyseat	Bore Range	Keyseat
0.375 / 0.500	0.125 X 0.063	6-7-8	2
0.625 / 0.875	0.188 X 0.094	9-10	3
0.938 / 1.250	0.250 X 0.125	11-12	4
1.313 / 1.375	0.313 X 0.156	13 THRU 17	5
1.438 / 1.750	0.375 X 0.188	18 THRU 22	6
1.813 / 2.250	0.500 X 0.250	23 THRU 30	8
2.313 / 2.750	0.625 X 0.313	31 THRU 38	10
2.813 / 3.250	0.750 X 0.375	39 THRU 44	12
3.313 / 3.750	0.875 X 0.438	45 THRU 50	14
3.813 / 4.500	1.000 X 0.500	51 THRU 58	16
-	-	59 THRU 65	18
-	-	66 THRU 75	20
-	-	76 THRU 85	22

GUARDIAN MINIATURE JAW COUPLINGS

Guardian miniature jaw couplings are general purpose 3 piece couplings with a variable durometer spider elements. These couplings are assembled under a preload, and provide zero backlash to the limit of the element. They are commonly used for applications such as stepper drives, positioning slides, encoders, resolvers, and tachometers.

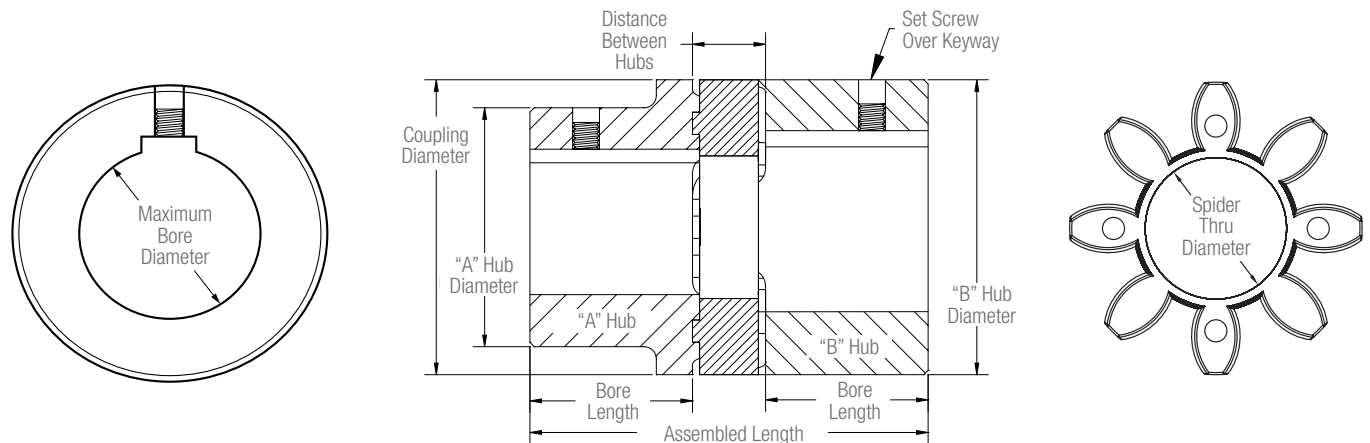

COUPLING DIMENSIONS

Aluminum Hubs

Size	"A" Hub Min/Max Bore	"B" Hub Min/Max Bore	"A" Hub Diameter	"B" Hub Diameter	Assembled Length	Bore Length	Between Hubs	Spider Thru Diameter	Misalignment		
									Axial	Parallel	Angular
7	N/A	Unbored / 7.0	N/A	14.0	21.8	7.1	0.4	Solid	0.8	0.1	1 Degree
9	N/A	Unbored / 9.0	N/A	19.8	30.5	9.9	0.6	Solid	0.8	0.1	1 Degree
14	N/A	Unbored / 16.0	N/A	30.0	34.3	10.9	12.4	Solid	0.8	0.1	1 Degree

COUPLING TORQUE RATINGS AND SPIDERS

Coupling Size	Spider Color	Torque (Newton meters)			Torsional Stiffness Newton meters/rad	Maximum Speed (RPM)*	KW @ 1800 RPM
		Nominal	Maximum	Backlash Free			
7-80	Blue	0.7	1.4	0.226	8.6	34,100	0.1
7-92	White	1.2	2.4		14.4	34,100	0.2
7-98	Red	2.0	4.0		2.9	34,100	0.4
7-64	Green	2.4	4.9		34.4	34,100	0.4
9-80	Blue	1.8	3.6	0.452	17.2	23,800	0.4
9-92	White	3.1	6.0		31.5	23,800	0.6
9-98	Red	5.0	10.1		51.5	23,800	1.0
9-64	Green	6.0	12.0		74.4	23,800	1.1
14-80	Blue	4.0	8.0	1.017	60.8	15,900	0.7
14-92	White	7.5	15.0		114.1	15,900	1.4
14-98	Red	12.5	25.0		171.5	15,900	2.4
14-64	Green	16.0	32.0		233.9	15,900	3.1

* Maximum speed ratings based upon set screw clamping. All other clamping methods please inquire to Guardian Engineering.

Guardian Couplings® CURVED JAW SELECTION PROCEDURE

Altra Industrial Motion

Drive shaft _____
 Drive keyway _____
 Driven shaft _____
 Driven keyway _____

KW _____
 RPM _____
 Temperature _____
 Starts/HR _____

STEP 1: Using the formula below calculate the nominal torque (Tn) of your application

$$T_n = (KW \times 9548) / RPM \text{ (Nm)}$$

STEP 2: Using the tables below select the service factors that best suit your application. After your selection calculate your service factor (S) by using the formula below.

$$S = S_1 \times S_2 \times S_3$$

STEP 3: Select a Guardian curved jaw coupling which has a nominal torque (Tkn) on page 2 equal to or greater than the nominal torque (Tn) value calculated in step 1 multiplied by the service factor (S) as shown below.

$$T_{kn} > T_n \times S$$

STEP 4: Verify the maximum permissible torque (Tkmax) which should be greater than or equal to the system peak torque (Stmax) multiplied by the temperature service factor (S2) as shown below.

$$T_{kmax} > S_{tmax} \times S_2$$

STEP 5: Verify the system speed is less than the maximum speed rating listed on page 2.

STEP 6: Verify the system misalignment with the rated misalignment of the coupling on page 4.

STEP 7: Verify min/max bore sizes of the selected coupling to the shaft sizes in your system. Also verify that dimensionally the coupling will fit in the envelop of the system.

Application Service Factors (S1)

Application	Service Factor (S1)
Uniform operation (small driven masses) i.e. Hydraulic pumps/motors, centrifugal fans	1.00
Uniform operation (medium driven masses) i.e. Axial piston pumps, mixers, blowers, conveyors, screw compressors	1.20
Non-uniform operation (medium driven masses) i.e. Shredders, generators, paper mills, conveyors, spinning machines, winches	1.50
Non-uniform operation (medium driven masses with light stock) i.e. Centrifuges, compression pumps, chain conveyors, concrete mixers, cable cars	1.60
Non-uniform operation (heavy driven masses with large stock) i.e. piston pumps, extruders, presses, rotary boring machines, hammer mills	1.80
Non-uniform operation (heavy driven masses with extreme shock) i.e. Reciprocating Compressors, Stone Crushers, Chippers	2.50

Temperature Service Factors (S2)

Temperature (C°)	-28.9/26.7	37.8	60	79.4
Service Factor S2	1.00	1.20	1.40	1.80

Starts Per Hour Service Factors (S3)

Starts/Hr	100	200	400	600
Service Factor S3	1.00	1.20	1.40	1.80

Definition of Terms

Term	Definition
Tn	Nominal torque of the system to be transmitted by the coupling
HP	Horsepower of the engine/motor
RPM	Driven speed of the application
S	Total service factor of the system
S1	Application service factor of the system
S2	Temperature service factor of the system
S3	Number of starts per hour service factor of the system
Tkn	Continuous nominal torque of the coupling
Tkmax	Maximum torque of the coupling
Stmax	Peak torque of the system to be transmitted by the coupling

These service factors are for general guidance only and are complimentary to customers knowledge of their own equipment. For further assistance in selecting a coupling please contact our engineering department at 219-874-5248.

Belted Drives and Sheaves	Couplings Cont.	Gearing	Linear Products
<p>TB Wood's <i>Belted Drives</i> Chambersburg, PA - USA 1-888-829-6637 – Press #5 <i>For application assistance:</i> 1-888-829-6637 – Press #7</p>	<p>TB Wood's <i>Elastomeric Couplings</i> Chambersburg, PA - USA 1-888-829-6637 – Press #5 <i>For application assistance:</i> 1-888-829-6637 – Press #7 <i>General Purpose Disc Couplings</i> San Marcos, TX - USA 1-888-449-9439</p>	<p>Bauer Gear Motor <i>Geared Motors</i> Esslingen, Germany +49 (711) 3518-0 Middlesex, NJ - USA 1-732-469-8770</p> <p>Boston Gear <i>Enclosed and Open Gearing, Electrical and Mechanical P.T. Components</i> Charlotte, NC - USA 1-800-825-6544 <i>For application assistance:</i> 1-800-816-5608</p> <p>Nuttall Gear and Delroyd Worm Gear <i>Worm Gear and Helical Speed Reducers</i> Niagara Falls, NY - USA 1-716-298-4100</p>	<p>Warner Linear <i>Linear Actuators</i> New Hartford, CT - USA 1-800-825-6544 <i>For application assistance:</i> 1-800-825-9050 Saint Barthélemy d'Anjou, France +33 (0)2 41 21 24 24</p>
<p>Couplings</p> <p>Ameridrives <i>Mill Spindles, Ameriflex, Ameridisc</i> Erie, PA - USA 1-814-480-5000 <i>Gear Couplings</i> San Marcos, TX - USA 1-800-458-0887 <i>Universal Joints, Drive Shafts, Mill Gear Couplings</i> Erie, PA - USA 1-920-593-2444</p> <p>Bibby Turboflex <i>Disc, Gear, Grid Couplings, Overload Clutches</i> Dewsbury, England +44 (0) 1924 460801 Boksburg, South Africa +27(0) 11 918 4270</p> <p>Guardian Couplings <i>Engineered Flywheel Couplings, Engine Housings and Pump Mounts, Flexible Shaft Couplings</i> Michigan City, IN - USA 1-219-874-5248</p> <p>Huco <i>Precision Couplings and Air Motors</i> Hertford, England +44 (0) 1992 501900 Chambersburg, PA - USA 1-888-829-6637</p> <p>Lamiflex Couplings <i>Flexible Couplings, Bearing Isolators, and Coupling Guards</i> Cotia, SP - Brasil +55 (11) 4615-6300</p>	<p>Electromagnetic Clutches and Brakes</p> <p>Inertia Dynamics <i>Spring Set Brakes; Power On and Wrap Spring Clutch/Brakes</i> New Hartford, CT - USA 1-800-800-6445</p> <p>Matrix <i>Electromagnetic Clutches and Brakes, Pressure Operated Clutches and Brakes</i> Brechin, Scotland +44 (0) 1356 602000 New Hartford, CT - USA 1-800-825-6544</p> <p>Warner Electric <i>Electromagnetic Clutches and Brakes</i> New Hartford, CT - USA 1-800-825-6544 <i>For application assistance:</i> 1-800-825-9050 Saint Barthélemy d'Anjou, France +33 (0)2 41 21 24 24 <i>Precision Electric Coils and Electromagnetic Clutches and Brakes</i> Columbia City, IN - USA 1-260-244-6183</p>	<p>Heavy Duty Clutches and Brakes</p> <p>Industrial Clutch <i>Pneumatic and Oil Immersed Clutches and Brakes</i> Waukesha, WI - USA 1-262-547-3357</p> <p>Svendborg Brakes <i>Industrial Brakes and Brake Systems</i> Vejstrup, Denmark +45 63 255 255</p> <p>Twiflex <i>Caliper Brakes and Thrusters</i> Wichita Falls, TX - USA 1-844-723-3483 Twickenham, England +44 (0) 20 8894 1161</p> <p>Wichita Clutch <i>Pneumatic Clutches and Brakes</i> Wichita Falls, TX - USA 1-800-964-3262 Bedford, England +44 (0) 1234 350311</p>	<p>Overrunning Clutches</p> <p>Formsprag Clutch <i>Overrunning Clutches and Holdbacks</i> Warren, MI - USA 1-800-348-0881 – Press #1 <i>For application assistance:</i> 1-800-348-0681 – Press #2</p> <p>Marland Clutch <i>Roller Ramp and Sprag Type Overrunning Clutches and Backstops</i> Warren, MI - USA 1-800-216-3515</p> <p>Stieber Clutch <i>Overrunning Clutches and Holdbacks</i> Heidelberg, Germany +49 (0) 6221-30470</p> <p><i>For information concerning our sales offices in Asia Pacific check our website www.altramotion.com.cn</i></p>

While Guardian Industries makes every effort to ensure the accuracy of the information provided, we make no warranty as to the accuracy or completeness of said information.



www.guardiancouplings.com

300 Indiana Highway 212
Michigan City, IN 46360 – USA
219-874-5248

Merchant Drive, Hertford
Hertfordshire SG13 7BL - England
+44(0)1992 501900