



# Curved Jaw Couplings

Measurements in  
Imperial Units



## Why Choose Guardian?

For more than 70 years, Guardian has been designing and manufacturing world-class couplings and other power transmission components. Utilizing advanced manufacturing technologies and processes, Guardian provides highly-reliable coupling and component solutions to meet the most challenging industrial application requirements.

Guardian provides a wide range of standard and custom products including flywheel couplings, hydraulic pump mounts, bearing supported stub shafts, flexible shaft-to-shaft couplings, motion control couplings as well as compression pipe couplings.

Durable Guardian products are utilized in key industries including mobile hydraulics, farm & ag, tree care, concrete, food & beverage, material handling, automation, power generation, and oil & gas on applications such as skid steers, aerial lifts, harvesters, wood chippers, concrete pumps, dewatering pumps, baggage handlers, conveyors, robotics, compressors, and generator sets.

## FEATURES AND ADVANTAGES

The Curved Jaw couplings can be utilized in many applications and serve as an all-purpose coupling. The basic design of the Curved Jaw allows for a higher torque capacity in a compact design. The curved tooth has a greater contact area which gives it the high torque capacity, and reduces edge pressure. It will accommodate axial, radial and angular shaft misalignments.

The hubs are produced from a variety of materials including: aluminum, gray iron, steel, sintered steel, and stainless steel. The spider elements are available in various durometer options in Urethane & Hytrel. The spiders can perform under normal duty cycle conditions to heavy duty cycles which include shock loading and can minimize torsional vibrations in the system.



- **Three Piece Design**
- **Fail Safe**
- **No Lubrication Required**
- **Variable Durometer Urethane Elements**
- **No Metal to Metal Contact**
- **High Torque Capacities**
- **Variable Hub Materials**

## COUPLING TORQUE RATINGS AND SPIDERS

The curved jaw coupling includes two metal hubs and an elastomeric “spider” element. The spiders are available in different hardness durometers, each easily identified by its color.

SPIDER CHARACTERISTICS					
Hardness	Color	Material	Temperature Range		Applications
			Standard	Maximum	
80 Shore A	Blue	Polyurethane	-40° to 212° F	250° F	Excellent damping
92 Shore A	White	Polyurethane	-40° to 212° F	250° F	Moderate damping, general applications
98 Shore A	Red	Polyurethane	-40° to 212° F	250° F	High torque applications
64 Shore D	Green	Hytrel	-30° to 230° F	266° F	Higher torque, high temperature

Coupling Size	Spider Color	Torque (inch-pounds)			Maximum Speed (RPM)	HP @ 1800 RPM
		Nominal	Maximum	Reversing		
19/24	Blue	43	86	11	14,000	1.2
19/24	White	89	170	23	14,000	2.5
19/24	Red	150	300	39	14,000	4.3
19/24	Green	185	370	46	14,000	5.3
24/32	Blue	151	301	39	10,600	4.3
24/32	White	300	610	80	10,600	8.6
24/32	Red	530	1,060	142	10,600	15
24/32	Green	660	1,320	165	10,600	19
28/38	Blue	407	814	106	8,500	12
28/38	White	840	1,680	221	8,500	24
28/38	Red	1,410	2,830	381	8,500	40
28/38	Green	1,770	3,540	442	8,500	51
38/45	Blue	823	1,637	212	7,100	24
38/45	White	1,680	3,360	434	7,100	48
38/45	Red	2,870	5,750	770	7,100	82
38/45	Green	3,585	7,170	896	7,100	102
38/45-L	Blue	823	1,637	212	7,100	24
38/45-L	White	1,680	3,360	434	7,100	48
38/45-L	Red	2,870	5,750	770	7,100	82
38/45-L	Green	3,585	7,170	896	7,100	102
42/55	Blue	1,151	2,301	301	6,000	33
42/55	White	2,340	4,690	611	6,000	67
42/55	Red	3,980	7,960	1,062	6,000	114
42/55	Green	4,955	9,910	1,238	6,000	142
42/55-L	Blue	1,151	2,301	301	6,000	33
42/55-L	White	2,340	4,690	611	6,000	67
42/55-L	Red	3,980	7,960	1,062	6,000	114
42/55-L	Green	4,955	9,910	1,238	6,000	142
48/60	Blue	1,328	2,655	345	5,600	38
48/60	White	2,740	5,450	540	5,600	78
48/60	Red	4,640	9,290	1,212	5,600	133
48/60	Green	5,795	11,590	1,448	5,600	166
55/70	White	3,620	7,250	823	4,750	103
55/70	Red	6,060	12,120	1,443	4,750	173
55/70	Green	7,300	14,600	1,825	4,750	208
65/75	White	5,530	11,060	982	4,250	158
65/75	Red	8,310	16,630	1,469	4,250	237
75/90	White	11,320	22,650	2,248	3,550	323
75/90	Red	16,990	33,980	3,372	3,550	485
90/100	White	21,240	42,480	5,522	3,550	607
90/100	Red	31,860	63,720	8,284	3,550	910
100/110	White	29,200	58,410	7,593	3,550	834
100/110	Red	43,810	87,620	11,390	3,550	1,251
110/125	White	42,480	84,960	9,204	3,550	1,213
110/125	Red	63,720	127,450	13,806	3,550	1,820
125/145	White	58,850	117,710	11,505	3,550	1,681
125/145	Red	88,510	177,000	17,258	3,550	2,528

## COUPLING DIMENSIONS

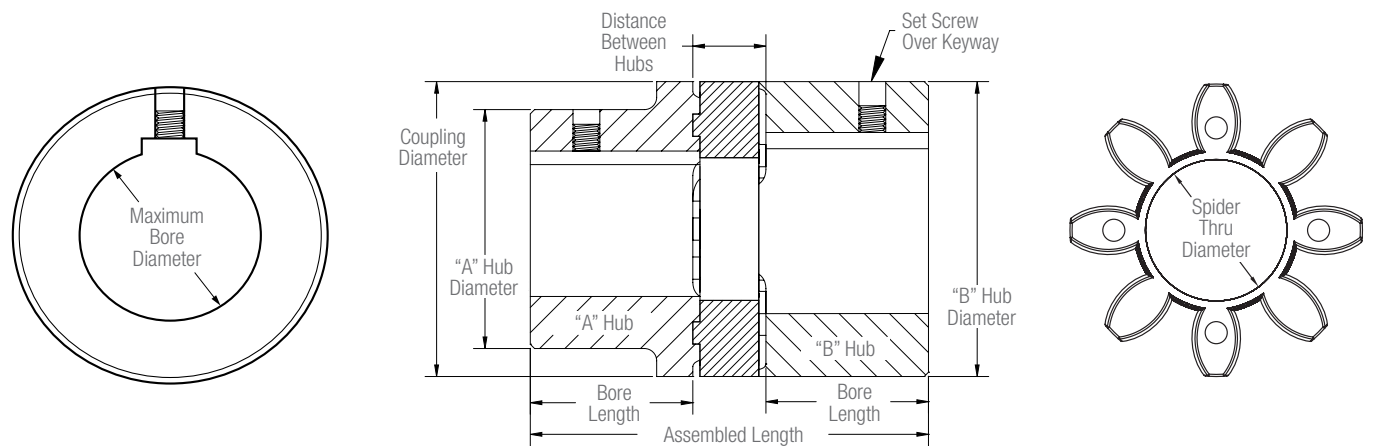

### Aluminum Hubs

Size	"A" Hub Min/Max Bore	"B" Hub Min/Max Bore	"A" Hub Diameter	"B" Hub Diameter	Coupling Diameter	Assembled Length	Bore Length (Both A & B)	Between Hubs	Spider Thru Diameter
19/24	.25"/.75"	0.25"/0.95"	1.26"	1.57"	1.57"	2.55"	0.98"	0.56"	0.70"
24/32	Unbored/.94"	0.32"/1.26"	1.86"	N/A	2.16"	2.97"	1.16"	0.63"	1.04"
28/38	.37"/1.10"	0.37"/1.50"	1.89"	2.55"	2.55"	3.53"	1.40"	0.73"	1.17"
38/45	Unbored/1.50"	Unbored/1.77"	2.60"	3.11"	3.11"	4.50"	1.77"	0.95"	1.57"
42/55	.60"/1.65"	0.60"/2.17"	2.95"	3.74"	3.74"	5.00"	2.00"	1.02"	1.86"
48/60	.50"/1.89"	0.50"/2.36"	3.35"	4.13"	4.13"	5.51"	2.27"	1.10"	1.91"

### Sintered Steel Hubs

Size	"A" Hub Min/Max Bore	"B" Hub Min/Max Bore	"A" Hub Diameter	"B" Hub Diameter	Coupling Diameter	Assembled Length	Bore Length (Both A & B)	Between Hubs	Spider Thru Diameter
19/24	N/A	Unbored/0.95"	N/A	1.57"	1.57"	2.55"	0.98"	0.56"	0.70"
24/32	N/A	Unbored/1.26"	N/A	2.18"	2.18"	3.03"	1.18"	0.63"	1.04"
28/38	N/A	Unbored/1.50"	N/A	2.56"	2.56"	3.45"	1.37"	0.73"	1.17"

### Stainless Steel Hubs

Size	"A" Hub Min/Max Bore	"B" Hub Min/Max Bore	"A" Hub Diameter	"B" Hub Diameter	Coupling Diameter	Assembled Length	Bore Length (Both A & B)	Between Hubs	Spider Thru Diameter
24/32	N/A	Unbored/1.26"	N/A	2.18"	2.18"	3.03"	1.18"	0.63"	0.70"
28/38	N/A	.50"/1.50"	N/A	2.56"	2.56"	3.45"	1.37"	0.73"	1.17"
38/45	N/A	.50"/1.77"	N/A	3.15"	3.15"	4.50"	1.77"	0.95"	1.57"
48/60	N/A	.50"/2.36"	N/A	4.13"	4.13"	5.51"	2.27"	1.10"	1.91"

### Steel Hubs

Size	"A" Hub Min/Max Bore	"B" Hub Min/Max Bore	"A" Hub Diameter	"B" Hub Diameter	Coupling Diameter	Assembled Length	Bore Length (Both A & B)	Between Hubs	Spider Thru Diameter
38/45	.50"/1.50"	.50"/1.77"	2.60"	3.16"	3.16"	4.50"	1.77"	0.95"	1.57"
38/45-L	N/A	.50"/1.77"	N/A	3.16"	3.16"	6.50"	2.77"	0.95"	1.57"
42/55	.60"/1.65"	.60"/2.17"	2.95"	3.74"	3.74"	5.00"	2.00"	1.02"	1.86"
42/55-L	N/A	.60"/2.17"	N/A	3.74"	3.74"	6.86"	2.95"	1.02"	1.86"
48/60	.50"/1.89"	.50"/2.36"	3.35"	4.13"	4.13"	5.51"	2.27"	1.10"	1.91"
55/70	.62"/2.17"	.62"/2.76"	3.86"	4.73"	4.73"	6.30"	2.56"	1.18"	2.38"
65/75	.87"/2.56"	.87"/2.95"	4.53"	5.31"	5.31"	7.28"	2.95"	1.38"	2.67"
75/90	1.00"/2.95"	1.00"/3.54"	5.32"	6.30"	6.30"	8.27"	3.37"	1.58"	3.61"
90/100	1.50"/3.54"	1.50"/3.94"	6.30"	7.08"	7.88"	9.65"	3.94"	1.77"	3.96"

### Cast Iron Hubs

Size	"A" Hub Min/Max Bore	"B" Hub Min/Max Bore	"A" Hub Diameter	"B" Hub Diameter	Coupling Diameter	Assembled Length	Bore Length (Both A & B)	Between Hubs	Spider Thru Diameter
90/100	1.50"/3.54"	1.50"/3.94"	6.30"	7.08"	7.88"	9.65"	3.94"	1.77"	3.96"
100/110	N/A	2.00"/4.33"	N/A	8.86"	8.86"	10.63"	4.33"	1.97"	4.35"
110/125	N/A	2.27"/4.92"	N/A	9.06"	10.04"	11.61"	4.72"	2.17"	4.90"
125/145	N/A	2.27"/5.71"	N/A	10.43"	11.42"	13.39"	5.51"	2.36"	5.75"



# MISALIGNMENT

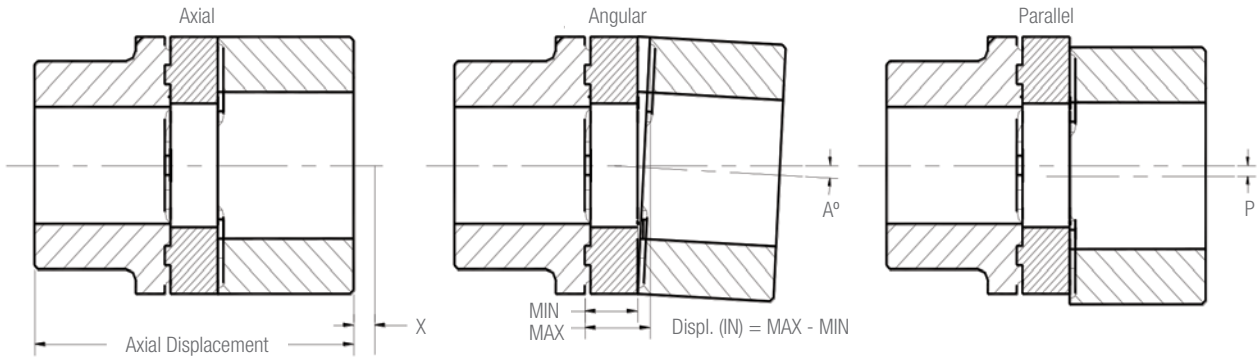

Size	Axial Displacement "X" (Inches)	Angular Displacement A° (Degrees/Inches)	Parallel Displacement P (Inches)
19/24	0.05	1.2 / 0.03	0.008
24/32	0.06	0.9 / 0.03	0.009
28/38	0.06	0.9 / 0.04	0.010
38/45	0.07	1.0 / 0.05	0.011
42/55	0.08	1.0 / 0.07	0.012
48/60	0.08	1.1 / 0.08	0.014
55/70	0.09	1.1 / 0.09	0.015
65/75	0.10	1.2 / 0.11	0.016
75/90	0.12	1.2 / 0.13	0.018
90/100	0.13	1.2 / 0.17	0.019
100/110	0.15	1.2 / 0.19	0.020
110/125	0.17	1.3 / 0.22	0.021
125/145	0.18	1.3 / 0.25	0.024

# SET SCREW / CLAMPING INFO

Coupling Size	19/24	24/32	28/38	38/45	42/55	48/60	55/70	65/75	75/90	90/100	100/110	110/125
Location (Y)	0.39	0.39	0.59	0.59	0.79	0.79	0.79	0.79	0.98	1.18	1.18	1.38
Set Screw (S)	1/4-20	5/16-18	5/16-18	5/16-18	3/8-16	3/8-16	1/2-13	1/2-13	1/2-13	3/4-10	3/4-10	3/4-10
Torque (FT-LBS)	7	14	14	14	23	23	50	50	50	167	167	167

# HUB OPTIONS

## Set Screw & Keyway\*

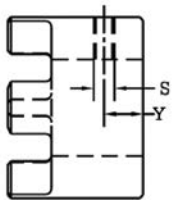

## Taper Lock Bushing

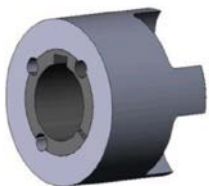

## Cross Clamp\*\*



\* Standard set screw furnished unless otherwise requested. Metric set screws also available.  
 \*\* SAE Spline with cross clamp feature is a standard offering.

# REFERENCE DATA

Standard Bores & Keyseats (in.)		Metric Bores & Keyseats (mm.)	
Bore Range	Keyseat	Bore Range	Keyseat
0.375 / 0.500	0.125 X 0.063	6-7-8	2
0.625 / 0.875	0.188 X 0.094	9-10	3
0.938 / 1.250	0.250 X 0.125	11-12	4
1.313 / 1.375	0.313 X 0.156	13 THRU 17	5
1.438 / 1.750	0.375 X 0.188	18 THRU 22	6
1.813 / 2.250	0.500 X 0.250	23 THRU 30	8
2.313 / 2.750	0.625 X 0.313	31 THRU 38	10
2.813 / 3.250	0.750 X 0.375	39 THRU 44	12
3.313 / 3.750	0.875 X 0.438	45 THRU 50	14
3.813 / 4.500	1.000 X 0.500	51 THRU 58	16
-	-	59 THRU 65	18
-	-	66 THRU 75	20
-	-	76 THRU 85	22

## GUARDIAN MINIATURE JAW COUPLINGS

Guardian miniature jaw couplings are general purpose 3 piece couplings with a variable durometer spider elements. These couplings are assembled under a preload, and provide zero backlash to the limit of the element. They are commonly used for applications such as stepper drives, positioning slides, encoders, resolvers, and tachometers.

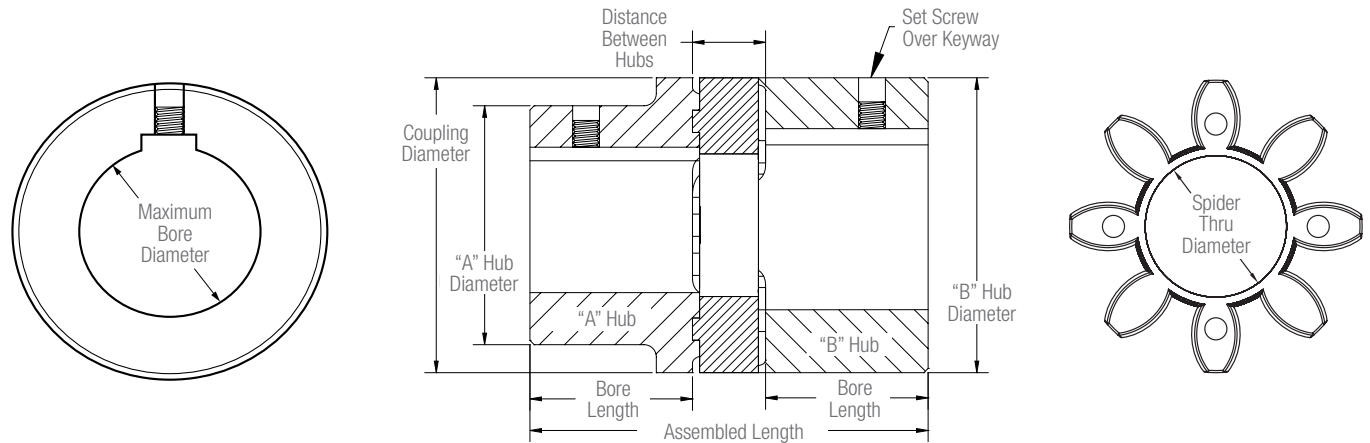

## COUPLING DIMENSIONS

### Aluminum Hubs

Size	"A" Hub Min/Max Bore	"B" Hub Min/Max Bore	"A" Hub Diameter	"B" Hub Diameter	Assembled Length	Bore Length	Between Hubs	Spider Thru Diameter	Misalignment		
									Axial	Parallel	Angular
7	N/A	Unbored / .276"	N/A	.55"	.86"	.28"	.30"	Solid	.030"	.002"	1 Degree
9	N/A	Unbored / .354"	N/A	.78"	1.20"	.39"	.42"	Solid	.030"	.002"	1 Degree
14	N/A	Unbored / .630"	N/A	1.18"	1.35"	.43"	.49"	Solid	.030"	.002"	1 Degree

## COUPLING TORQUE RATINGS AND SPIDERS

Coupling Size	Spider Color	Torque (inch-pounds)			Torsional Stiffness Inch-pounds/rad	Maximum Speed (RPM)*	HP @ 1800 RPM
		Nominal	Maximum	Backlash Free			
7-80	Blue	6	12		76	34,100	0.17
7-92	White	11	21	2	127	34,100	0.31
7-98	Red	18	35		203	34,100	0.51
7-64	Green	21	43		304	34,100	0.60
9-80	Blue	16	32		152	23,800	0.46
9-92	White	27	53	4	279	23,800	0.77
9-98	Red	44	89		456	23,800	1.26
9-64	Green	53	106		658	23,800	1.51
14-80	Blue	35	71		538	15,900	1.00
14-92	White	66	133	9	1010	15,900	1.88
14-98	Red	111	221		1518	15,900	3.17
14-64	Green	142	283		2070	15,900	4.06

\* Maximum speed ratings based upon set screw clamping. All other clamping methods please inquire to Guardian Engineering.

# Guardian Couplings® CURVED JAW SELECTION PROCEDURE

Altra Industrial Motion

Drive shaft \_\_\_\_\_  
 Drive keyway \_\_\_\_\_  
 Driven shaft \_\_\_\_\_  
 Driven keyway \_\_\_\_\_

HP \_\_\_\_\_  
 RPM \_\_\_\_\_  
 Temperature \_\_\_\_\_  
 Starts/HR \_\_\_\_\_

**STEP 1:** Using the formula below calculate the nominal torque (Tn) of your application

$$T_n = (HP \times 63,025) / RPM \text{ (IN-LBS)}$$

**STEP 2:** Using the tables below select the service factors that best suit your application. After your selection calculate your service factor (S) by using the formula below.

$$S = S_1 \times S_2 \times S_3$$

**STEP 3:** Select a Guardian curved jaw coupling which has a nominal torque (Tkn) on page 2 equal to or greater than the nominal torque (Tn) value calculated in step 1 multiplied by the service factor (S) as shown below.

$$T_{kn} > T_n \times S \text{ (IN-LBS)}$$

**STEP 4:** Verify the maximum permissible torque (Tkmax) which should be greater than or equal to the system peak torque (Stmax) multiplied by the temperature service factor (S2) as shown below.

$$T_{kmax} > S_{tmax} \times S_2 \text{ (IN-LBS)}$$

**STEP 5:** Verify the system speed is less than the maximum speed rating listed on page 2.

**STEP 6:** Verify the system misalignment with the rated misalignment of the coupling on page 4.

**STEP 7:** Verify min/max bore sizes of the selected coupling to the shaft sizes in your system. Also verify that dimensionally the coupling will fit in the envelop of the system.

## Application Service Factors (S1)

Application	Service Factor (S1)
<b>Uniform operation (small driven masses)</b> i.e. Hydraulic pumps/motors, centrifugal fans	1.00
<b>Uniform operation (medium driven masses)</b> i.e. Axial piston pumps, mixers, blowers, conveyors, screw compressors	1.20
<b>Non-uniform operation (medium driven masses)</b> i.e. Shredders, generators, paper mills, conveyors, spinning machines, winches	1.50
<b>Non-uniform operation (medium driven masses with light stock)</b> i.e. Centrifuges, compression pumps, chain conveyors, concrete mixers, cable cars	1.60
<b>Non-uniform operation (heavy driven masses with large stock)</b> i.e. piston pumps, extruders, presses, rotary boring machines, hammer mills	1.80
<b>Non-uniform operation (heavy driven masses with extreme shock)</b> i.e. Reciprocating Compressors, Stone Crushers, Chippers	2.50

## Temperature Service Factors (S2)

Temperature (F°)	-20/80	100	140	175
<b>Service Factor S2</b>	1.00	1.20	1.40	1.80

## Starts Per Hour Service Factors (S3)

Starts/Hr	100	200	400	600
<b>Service Factor S3</b>	1.00	1.20	1.40	1.80

## Definition of Terms

Term	Definition
<b>Tn</b>	Nominal torque of the system to be transmitted by the coupling
<b>HP</b>	Horsepower of the engine/motor
<b>RPM</b>	Driven speed of the application
<b>S</b>	Total service factor of the system
<b>S1</b>	Application service factor of the system
<b>S2</b>	Temperature service factor of the system
<b>S3</b>	Number of starts per hour service factor of the system
<b>Tkn</b>	Continuous nominal torque of the coupling
<b>Tkmax</b>	Maximum torque of the coupling
<b>Stmax</b>	Peak torque of the system to be transmitted by the coupling

These service factors are for general guidance only and are complimentary to customers knowledge of their own equipment. For further assistance in selecting a coupling please contact our engineering department at 219-874-5248.

Belted Drives and Sheaves	Couplings Cont.	Gearing	Linear Products
<p><b>TB Wood's</b> <i>Belted Drives</i> Chambersburg, PA - USA <b>1-888-829-6637</b> – Press #5 <i>For application assistance:</i> <i>1-888-829-6637 – Press #7</i></p>	<p><b>TB Wood's</b> <i>Elastomeric Couplings</i> Chambersburg, PA - USA <b>1-888-829-6637</b> – Press #5 <i>For application assistance:</i> <i>1-888-829-6637 – Press #7</i> <i>General Purpose Disc Couplings</i> San Marcos, TX - USA <b>1-888-449-9439</b></p>	<p><b>Bauer Gear Motor</b> <i>Geared Motors</i> Esslingen, Germany <b>+49 (711) 3518-0</b> Middlesex, NJ - USA <b>1-732-469-8770</b></p> <p><b>Boston Gear</b> <i>Enclosed and Open Gearing, Electrical and Mechanical P.T. Components</i> Charlotte, NC - USA <b>1-800-825-6544</b> <i>For application assistance:</i> <i>1-800-816-5608</i></p> <p><b>Nuttall Gear and Delroyd Worm Gear</b> <i>Worm Gear and Helical Speed Reducers</i> Niagara Falls, NY - USA <b>1-716-298-4100</b></p>	<p><b>Warner Linear</b> <i>Linear Actuators</i> New Hartford, CT - USA <b>1-800-825-6544</b> <i>For application assistance:</i> <i>1-800-825-9050</i> Saint Barthélemy d'Anjou, France <b>+33 (0)2 41 21 24 24</b></p>
<p><b>Couplings</b></p> <p><b>Ameridrives</b> <i>Mill Spindles, Ameriflex, Ameridisc</i> Erie, PA - USA <b>1-814-480-5000</b> <i>Gear Couplings</i> San Marcos, TX - USA <b>1-800-458-0887</b> <i>Universal Joints, Drive Shafts, Mill Gear Couplings</i> Erie, PA - USA <b>1-920-593-2444</b></p> <p><b>Bibby Turboflex</b> <i>Disc, Gear, Grid Couplings, Overload Clutches</i> Dewsbury, England <b>+44 (0) 1924 460801</b> Boksburg, South Africa <b>+27(0) 11 918 4270</b></p> <p><b>Guardian Couplings</b> <i>Engineered Flywheel Couplings, Engine Housings and Pump Mounts, Flexible Shaft Couplings</i> Michigan City, IN - USA <b>1-219-874-5248</b></p> <p><b>Huco</b> <i>Precision Couplings and Air Motors</i> Hertford, England <b>+44 (0) 1992 501900</b> Chambersburg, PA - USA <b>1-888-829-6637</b></p> <p><b>Lamiflex Couplings</b> <i>Flexible Couplings, Bearing Isolators, and Coupling Guards</i> Cotia, SP - Brasil <b>+55 (11) 4615-6300</b></p>	<p><b>Electromagnetic Clutches and Brakes</b></p> <p><b>Inertia Dynamics</b> <i>Spring Set Brakes; Power On and Wrap Spring Clutch/Brakes</i> New Hartford, CT - USA <b>1-800-800-6445</b></p> <p><b>Matrix</b> <i>Electromagnetic Clutches and Brakes, Pressure Operated Clutches and Brakes</i> Brechin, Scotland <b>+44 (0) 1356 602000</b> New Hartford, CT - USA <b>1-800-825-6544</b></p> <p><b>Warner Electric</b> <i>Electromagnetic Clutches and Brakes</i> New Hartford, CT - USA <b>1-800-825-6544</b> <i>For application assistance:</i> <i>1-800-825-9050</i> Saint Barthélemy d'Anjou, France <b>+33 (0)2 41 21 24 24</b> <i>Precision Electric Coils and Electromagnetic Clutches and Brakes</i> Columbia City, IN - USA <b>1-260-244-6183</b></p>	<p><b>Heavy Duty Clutches and Brakes</b></p> <p><b>Industrial Clutch</b> <i>Pneumatic and Oil Immersed Clutches and Brakes</i> Waukesha, WI - USA <b>1-262-547-3357</b></p> <p><b>Svendborg Brakes</b> <i>Industrial Brakes and Brake Systems</i> Vejstrup, Denmark <b>+45 63 255 255</b></p> <p><b>Twiflex</b> <i>Caliper Brakes and Thrusters</i> Wichita Falls, TX - USA <b>1-844-723-3483</b> Twickenham, England <b>+44 (0) 20 8894 1161</b></p> <p><b>Wichita Clutch</b> <i>Pneumatic Clutches and Brakes</i> Wichita Falls, TX - USA <b>1-800-964-3262</b> Bedford, England <b>+44 (0) 1234 350311</b></p>	<p><b>Overrunning Clutches</b></p> <p><b>Formsprag Clutch</b> <i>Overrunning Clutches and Holdbacks</i> Warren, MI - USA <b>1-800-348-0881</b> – Press #1 <i>For application assistance:</i> <i>1-800-348-0881 – Press #2</i></p> <p><b>Marland Clutch</b> <i>Roller Ramp and Sprag Type Overrunning Clutches and Backstops</i> Warren, MI - USA <b>1-800-216-3515</b></p> <p><b>Stieber Clutch</b> <i>Overrunning Clutches and Holdbacks</i> Heidelberg, Germany <b>+49 (0) 6221-30470</b></p> <p><i>For information concerning our sales offices in Asia Pacific check our website <a href="http://www.altramotion.com.cn">www.altramotion.com.cn</a></i></p>

While Guardian Industries makes every effort to ensure the accuracy of the information provided, we make no warranty as to the accuracy or completeness of said information.



[www.guardiancouplings.com](http://www.guardiancouplings.com)

300 Indiana Highway 212  
Michigan City, IN 46360 – USA  
219-874-5248

Merchant Drive, Hertford  
Hertfordshire SG13 7BL - England  
+44(0)1992 501900