



**Straight Jaw
Couplings
LJW
SWJW**



GUARDIAN COUPLINGS™

A REGAL REXNORD BRAND

GUARDIAN COUPLINGS LJW & SWJW JAW COUPLINGS

LJW Flexible Straight Jaw Couplings

The LJW coupling is your basic industry standard jaw coupling, and is completely interchangeable to other popular manufactures. Guardian offers the LJW as a standard in steel and cast iron, but if required can also be produced from other materials. It features three material types on the spiders which include Buna-N, Urethane, and Hytrel. The LJW is a very economical solution, and will accommodate axial, radial and angular shaft misalignments.



SWJW Single Wrap Jaw Couplings

The Guardian SWJW coupling is identical to the LJW Straight Jaw, except that the spider element wraps around the jaw tooth circumference, and is held in place with a steel retaining band. This design eliminates the need to relocate the prime mover/driven unit, and saves a remarkable amount of maintenance time.



Features & Advantages

- Three Piece Design (LJW only)
- Change-in-Place Design
- No Lubrication Required
- Variable Durometer Elements
- No metal to metal contact
- High Torque Capacities
- Interchangeable to other domestic brands

Coupling Torque Ratings And Spiders

The straight jaw coupling includes two metal hubs and an elastomeric "spider" element. The spiders are available in different hardness durometers, each easily identified by its color.

SPIDER CHARACTERISTICS						
Hardness	Color	Material	Temperature Range ° F	Applications	Misalignment	
					Angular	Parallel
80 Shore A	Black	Buna-N	-40° to 212° F	Excellent damping	1°	0.015
55 Shore D (LJW L050-L110)	Orange	Urethane	-30° to 160° F	High torque applications	1°	0.015
90-95 Shore A (LJW L150-L225)	Orange	Urethane	-30° to 160° F	High torque applications	1°	0.015
55 Shore D	White	Hytrel	-60° to 250° F	Higher torque, high temperature	.5°	0.015

Coupling Size	Spider Color	Torque (inch-pounds)	Maximum Speed (RPM)*	HP @ 1800 RPM
LJW L050	Black	26	18,000	0.74
LJW L050	Orange	39	18,000	1.11
LJW L050	White	50	18,000	1.43
LJW L070	Black	43	14,000	1.23
LJW L070	Orange	65	3,600	1.86
LJW L070	White	114	3,600	3.26
LJW L075	Black	90	11,000	2.57
LJW L075	Orange	135	3,600	3.86
LJW L075	White	227	3,600	6.48
LJW L090	Black	144	9,000	4.11
LJW L090	Orange	216	3,600	6.17
LJW L090	White	401	3,600	11.45
SWJW L090	Black	144	3,600	4.11
LJW L095	Black	194	7,000	5.54
LJW L095	Orange	291	3,600	8.31
LJW L095	White	561	3,600	16.02
SWJW L095	Black	194	3,600	5.54
LJW L099	Black	318	7,000	9.08
LJW L099	Orange	477	3,600	13.62
LJW L099	White	792	3,600	22.62
SWJW L099	Black	318	3,600	9.08
LJW L100	Black	417	7,000	11.91
LJW L100	Orange	626	3,600	17.88
LJW L100	White	1,134	3,600	32.39
SWJW L100	Black	417	3,600	11.91
LJW L110	Black	792	5,000	22.62
LJW L110	Orange	1,188	5,000	33.93
LJW L110	White	2,268	5,000	64.77
SWJW L110	Black	792	3,600	22.62
LJW L150	Black	1,240	5,000	35.41
LJW L150	Orange	1,860	5,000	53.12
LJW L150	White	3,708	5,000	105.9
SWJW L150	Black	1,240	3,600	35.41
LJW L190	Black	1,726	5,000	49.29
LJW L190	Orange	2,592	5,000	74.03
LJW L190	White	4,680	5,000	133.66
SWJW L190	Black	1,726	3,600	49.29
LJW L225	Black	2,340	4,200	66.83
LJW L225	Orange	3,510	4,200	100.25
LJW L225	White	6,228	4,200	177.87
SWJW L225	Black	2,340	3,600	66.83

* Open center spiders are available, but have a lower RPM capacity (1,750 RPM maximum for Buna-N, 3,600 maximum for Urethane and Hytrel).

* SWJW collars allow for a maximum speed rating of 3,600 RPM. The spiders are only available in Buna-N for this series; the hubs are drilled and tapped to accept collar mounting screws.

GUARDIAN COUPLINGS STRAIGHT JAW SELECTION PROCEDURE

Drive shaft _____ HP _____
 Drive keyway _____ RPM _____
 Driven shaft _____ Temperature _____
 Driven keyway _____ Starts/HR _____

STEP 1: Using the formula below calculate the nominal torque (Tn) of your application

$$T_n = (HP \times 63,025) / RPM \text{ (IN-LBS)}$$

STEP 2: Using the tables below select the service factors that best suit your application. After your selection calculate your service factor (S) by using the formula below.

$$S = S_1 \times S_2 \times S_3$$

STEP 3: Select a Guardian straight jaw coupling which has a nominal torque (Tkn) on page 1 equal to or greater than the nominal torque (Tn) value calculated in step 1 multiplied by the service factor (S) as shown below.

$$T_{kn} > T_n \times S \text{ (IN-LBS)}$$

STEP 4: Verify the maximum permissible torque (Tkmax) which should be greater than or equal to the system peak torque (Stmax) multiplied by the temperature service factor (S2) as shown below.

$$T_{kmax} > S_{tmax} \times S_2 \text{ (IN-LBS)}$$

STEP 5: Verify the system speed is less than the maximum speed rating listed on page 1.

STEP 6: Verify the system misalignment with the rated misalignment of the coupling on page 1.

STEP 7: Verify min/max bore sizes of the selected coupling to the shaft sizes in your system. Also verify that dimensionally the coupling will fit in the envelop of the system.

Application Service Factors (S1)

Application	Service Factor (S1)
Uniform operation (small driven masses) i.e.: Hydraulic pumps/motors, centrifugal fans	1.00
Uniform operation (medium driven masses) i.e.: Axial piston pumps, mixers, blowers, conveyors, screw compressors	1.20
Non-uniform operation (medium driven masses) i.e.: Shredders, generators, paper mills, conveyors, spinning machines, winches	1.50
Non-uniform operation (medium driven masses w/ light stock) i.e.: Centrifuges, compression pumps, chain conveyors, concrete mixers, cable cars	1.60
Non-uniform operation (heavy driven masses w/ large stock) i.e.: piston pumps, extruders, presses, rotary boring machines, hammer mills	1.80
Non-uniform operation (heavy driven masses w/ extreme shock) i.e.: Reciprocating Compressors, Stone Crushers, Chippers	2.50

Temperature Service Factors (S2)

Temperature (F)	-20/80	100	140	175
Service Factor S2	1.00	1.20	1.40	1.80

Starts Per Hour Service Factors (S3)

Starts/Hr	100	200	400	600
Service Factor S3	1.00	1.20	1.40	1.80

Definition of Terms

Term	Definition
Tn	Nominal torque of the system to be transmitted by the coupling
HP	Horsepower of the engine/motor
RPM	Driven speed of the application
S	Total service factor of the system
S1	Application service factor of the system
S2	Temperature service factor of the system
S3	Number of starts per hour service factor of the system
Tkn	Continuous nominal torque of the coupling
Tkmax	Maximum torque of the coupling
Stmax	Peak torque of the system to be transmitted by the coupling

These service factors are for general guidance only and are complimentary to customers knowledge of their own equipment. For further assistance in selecting a coupling please contact our engineering department at 219-874-5248.

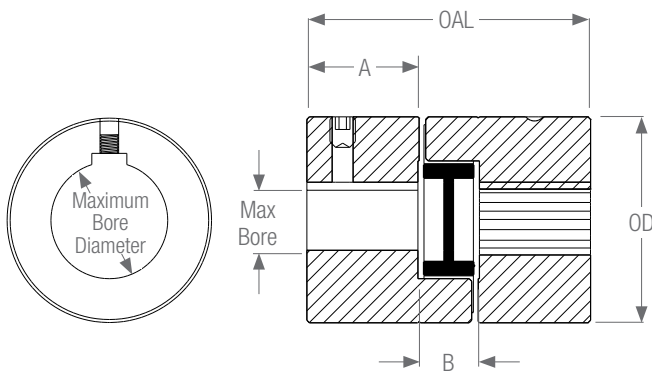

LJW

Size	Max Bore	Coupling Diameter (OD)	Assembled Length (OAL)	Bore Length (A)	Between Hubs (B)
LJW L050	0.63	1.08	1.72	.62	.48
LJW L070	0.75	1.36	1.98	.75	.48
LJW L075	0.88	1.75	2.14	.82	.50
LJW L090	1.00	2.11	2.18	.82	.54
LJW L095	1.13	2.11	2.54	1.00	.54
LJW L099	1.19	2.54	2.85	1.06	.73
LJW L100	1.38	2.54	3.49	1.38	.73
LJW L110	1.63	3.32	4.24	1.68	.88
LJW L150	1.88	3.75	4.50	1.75	1.00
LJW L190	2.13	4.50	5.28	2.14	1.00
LJW L225	2.63	5.00	6.02	2.51	1.00

SWJW

Size	Max Bore	Coupling Diameter (OD)	Assembled Length (OAL)	Bore Length (A)	Between Hubs (B)
SWJW L090	1.00	2.56	2.18	.82	.54
SWJW L095	1.13	2.56	2.54	1.00	.54
SWJW L099	1.19	3.07	2.85	1.06	.73
SWJW L100	1.38	3.07	3.49	1.38	.73
SWJW L110	1.63	3.78	4.24	1.68	.88
SWJW L150	1.88	4.37	4.50	1.75	1.00
SWJW L190	2.13	5.08	5.28	2.14	1.00
SWJW L225	2.63	5.60	6.02	2.51	1.00

All Hubs have a black phosphate treatment for superior corrosion resistance.

Aluminum and stainless steel hubs are available upon request, but are not commonly stocked.

Guardian manufactures standard imperial and metric bores in addition to a variety of common SAE type splines. DIN and JIS splines are also available upon request.

Special length hubs and configurations available upon request.

Guardian Couplings Facilities

North America

USA

300 Indiana Highway 212
Michigan City, IN 46360
219-874-5248

*Engineered Flywheel Couplings, Engine
Housings and Pump Mounts, Flexible
Shaft Couplings*

Europe

United Kingdom

Merchant Drive, Hertford
Hertfordshire SG13 7BL - England
+44(0)1992 501900

*Engineered Flywheel Couplings, Engine
Housings and Pump Mounts, Flexible
Shaft Couplings*

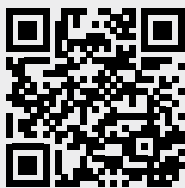

Scan to see all
the brands of
Regal Rexnord

Neither the accuracy nor completeness of the information contained in this publication is guaranteed by the company and may be subject to change in its sole discretion. The operating and performance characteristics of these products may vary depending on the application, installation, operating conditions and environmental factors. The company's terms and conditions of sale can be viewed at <http://www.altramotion.com/terms-and-conditions/sales-terms-and-conditions>. These terms and conditions apply to any person who may buy, acquire or use a product referred to herein, including any person who buys from a licensed distributor of these branded products.

©2023 by Guardian Couplings LLC. All rights reserved. All trademarks in this publication are the sole and exclusive property of Guardian Couplings LLC or one of its affiliated companies.